

Check Valve -- Type CK4A

Port Size 13 - 100mm (1/2" - 4")

For Ammonia, R12, R22, R502 and other common refrigerants

Features:

- UL Listed (Thru 3" Size)
- May be installed in any position
- Compact
- Lightweight
- Inline
- Design Pressure (MRP): 34.5 bar (500 psi)

"Not suitable for" discharge of reciprocating compressor or economizer port of screw compressor

Description

These compact valves are spring closing with a lapped, stainless steel or chrome plated seat for positive closing action and low leakage. A minimum pressure difference of 0.05 bar (0.75 psi) is required to hold the valve in the open position. Removable seat plate with combination O-ring and metal to metal knife edge seal allows the valve to be disassembled for maintenance. They may be ordered with male adapter rings for close-coupling to other Refrigerating Specialties valves and may be installed in any position.

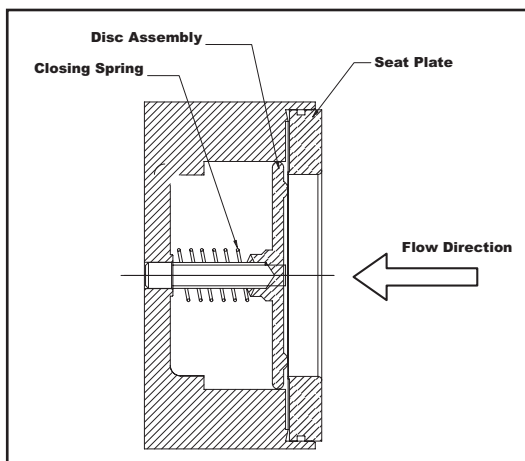

Figure 1

Purpose

The Type CK4A Check Valves prevent backward flow of fluid in refrigerant suction, hot gas or liquid lines. The most frequent use for these valves is in re-circulating (overfeed) systems. They are especially suited for high speed compressor discharge, pump discharge, suction temperatures down to -45°C (-50°F) and hot gas lines (pan to evaporator).

Certain refrigerant flows pulsate sufficiently or with a frequency in harmony with the valve's natural frequency, which can



cause "slapping" or even wholesale failure. These valves are not recommended for slow speed reciprocating compressor discharge lines (See CK1, Bulletin 50-10) or for any compressor discharge where a low speed machine discharges into the same downstream header, or for use on side port economizer lines on a screw compressor installation.

Operation

These are light spring-closing check valves. An increase in the pressure drop across the valve overcomes the force of the closing spring and the disc is forced away from its seat, permitting flow. As the flow decreases, the disc is forced back against the seat by the expansion of the closing spring. Flow is then stopped.

Installation

Keep dirt from entering the valve. Do not remove protective packaging until ready to install. Install the valve where it can be serviced easily. **DO NOT INSTALL CHECK VALVE AT THE INLET OF A SOLENOID VALVE, OR A REGULATOR WITH AN ELECTRIC SHUT-OFF FEATURE. DO NOT INSTALL AT THE INLET OF AN OUTLET PRESSURE REGULATOR IN A SYSTEM WHERE LIQUID MAY BE TRAPPED BETWEEN TWO VALVES.** When used in this application, Check Valves should always be installed at the outlet of the valves.

NOTE: THE ODS COPPER FLANGES THAT ARE AVAILABLE ARE ONLY FOR INSTALLATIONS WHERE R-12, R-22, AND R-502 OR OTHER HALOCARBON REFRIGERANTS ARE USED. DO NOT USE THESE FLANGES FOR AMMONIA. FOR INSTALLATIONS USING AMMONIA, THE FPT, SOCKET WELD, OR WELD NECK FLANGES SHOULD BE USED.

The Type CK4A Valves may be installed in any position. The valve must be installed with the arrow pointing in the direction of flow. After installing the valve, tighten the flange bolts evenly.

The CK4A Check Valves may be close-coupled to Refrigerating Specialties Refrigerant Valves by using a Refrigerating Specialties Male Adapter Ring.

Repair Kits for Type CK4A Check Valves

Item No.	Description	Qty	Port Size			
			50mm(2")	65mm (2-1/2")	75 mm (3")	100mm (4")
6	Valve Seat	1	Available Only with Kit			
7	O-Ring	1				
8	Disc Assembly	1				
9	Comp. Spring	1				
4	Flange Gasket	2				
4,6,7,8,9	Repair Kit	-	202089	202090	202091	202092
4	Flange Gasket Pkg.	12	202081	202082	202083	202084

Note: 13-32mm (1/2 - 1 1/4") do not have Repair Kits available

Dimensional Data

Dimension		Port Size																	
		13 mm (1/2")	20-25mm (3/4 - 1")		32mm (1-1/4")		50 mm (2")		65mm (2-1/2")	75mm (3")	100 mm (4")								
A	mm	75	113		95		114		148	148	179								
	inch	29.3	4.43		3.75		4.5		5.81	5.81	7.06								
B	mm	38	62		95		114		148	148	179								
	inch	1.5	2.43		3.75		4.5		5.81	5.81	7.06								
C	mm	27	32		50		60		70	81	89								
	inch	1.06	1.25		2		2.37		2.75	3.19	3.50								
D (FPT,SW)	mm	66	63		108		127		146	166	181								
	inch	2.64	2.52		4.25		4.99		5.75	6.53	7.125								
Conn Size		3/8, 1/2, 3/4		3/4"	1"	1-1/4"		1-1/4"	1-1/2"	1-1/2"	2"	2-1/2"	3"	4"					
E	mm	82		97	117	117		126	136	171	177	215		245	298				
	inch	3.22		3.82	4.61	4.61		4.97	5.35	6.72	6.97	8.47		9.66	11.72				
Conn Size		1/2	5/8	7/8	7/8	1-1/8	1-3/8	5/8	1-3/8	1-5/8	2-1/8	1-5/8	2-1/8	2-5/8	2-5/8	3-1/8	3-1/8	3-5/8	4-1/8
F	mm	76	82	98	99	193	99.5	111	119	130	159	193	177	205	203	250	228	248	285
	inch	2.98	3.22	3.85	3.88	4.07	3.91	4.36	4.69	5.12	6.26	7.57	6.95	8.08	7.98	9.82	8.95	9.76	11.2
N	mm	9	13	29	20	24	25	28	25	28	34	28	34	37	37	42	42	48	55
	inch	0.37	0.5	0.75	0.75	0.93	0.96	1.09	0.96	1.09	1.34	1.09	1.34	1.46	1.46	1.65	1.65	1.9	2.15

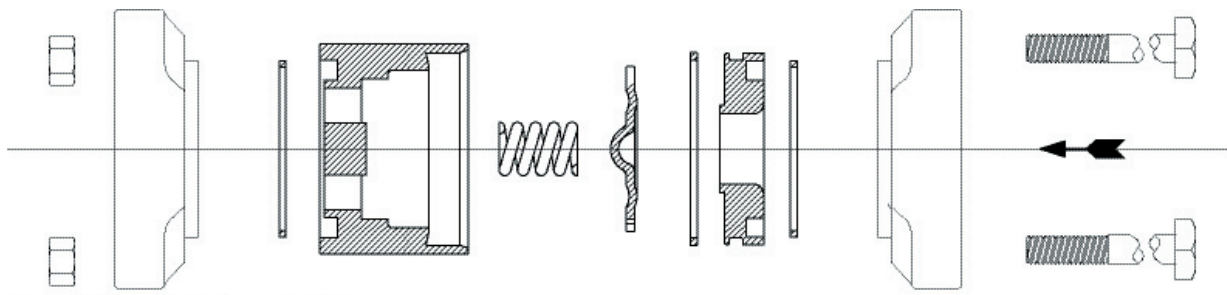

Type CK4A 1/2" thru 1-1/4"

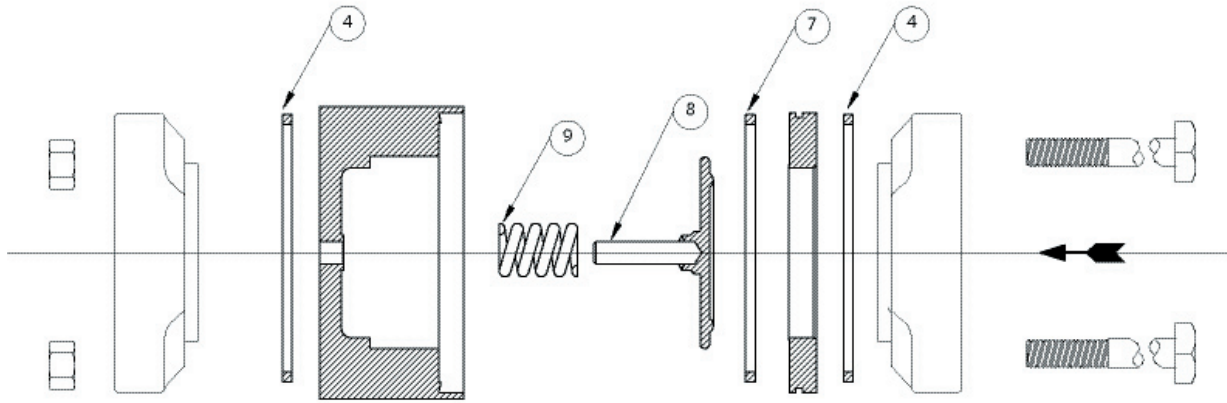

Type CK4A 2" thru 4"

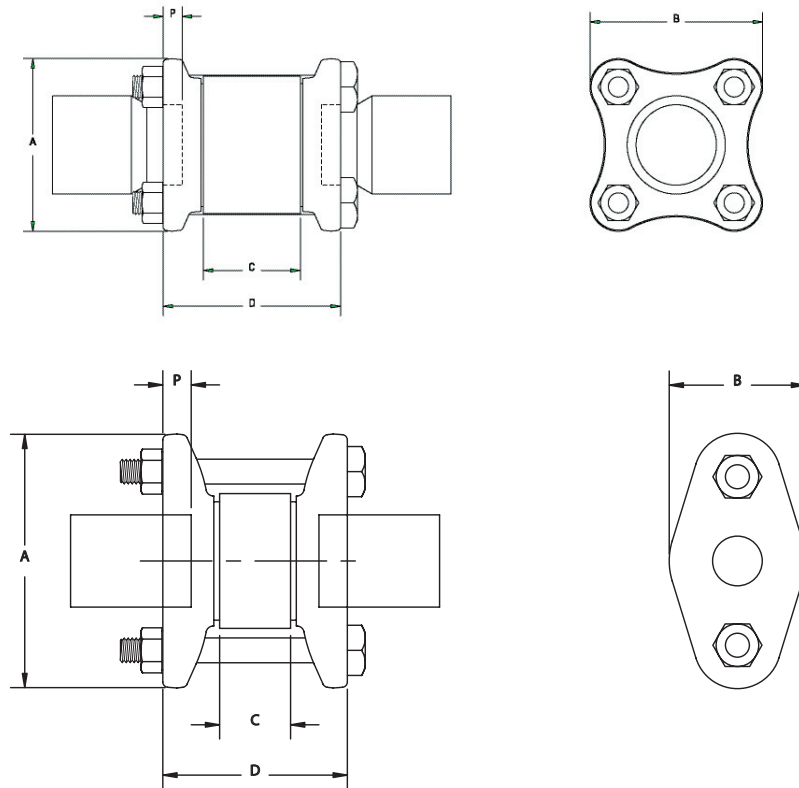

Service

Dirt or other foreign material in the system is the greatest single cause of valve malfunction.

Before disassembling a check valve for servicing, read and become familiar with the Safe Operation Instructions in this bulletin as well as in the current issue of Safety Bulletin RSB.

Check the following chart for possible symptoms and corrections.

Symptom	Probable Reason	Correction
Valve does not close or there is leakage through valve	Dirt or chips under valve seat.	Disassemble valve and clean thoroughly. Replace any damaged parts.
Valve chatters	Dirt or chips under valve seat. Valve may be Oversized.	Disassemble valve and clean thoroughly. Replace any damaged parts. Check sizing of valve. May have to replace with smaller port size or use Type CK1 check valve.

Disassembly

Caution: If the valve to be disassembled or removed is close-coupled to a solenoid operated valve, make sure that the power supply to the valve is de-energized and all refrigerant is pumped out of the line. Refer to Page 3 as necessary. After removing the valve from between the flanges, remove the parts in the numerical order shown in the applicable exploded view. In all CK4A Valves, the seat plates with the O-rings are removed by gently tapping out the seat from the opposite end of the valve body. Use a wooden dowel for this purpose.

Assembly

Before assembling, all parts must be clean, dry and lightly coated with refrigerant oil. If an existing refrigeration valve or strainer is close-coupled to the check valve, the valves should be opened, inspected and cleaned before putting either one back in service.

Refer to Page 3 as applicable. Assemble the valve in the reverse numerical order shown in the exploded view. Make sure the O-ring is firmly seated and permanently retained by the seat plate when re-assembled.

Warranty

All Refrigerating Specialties products are warranted against defects in workmanship and materials for a period of one year from date of shipment from originating factory. This warranty is in force only when products are properly installed, field assembled, maintained, and operated in use and service as

specifically stated in Refrigerating Specialties Catalogs or Bulletins for normal refrigeration applications, unless otherwise approved in writing by Refrigerating Specialties Division. Defective products, or parts thereof returned to the factory with transportation charges prepaid and found to be defective by factory inspection, will be replaced or repaired at Refrigerating Specialties option, free of charge, F.O.B. factory. Warranty does not cover products which have been altered, or repaired in the field; damaged in transit, or have suffered accidents, misuse, or abuse. Products disabled by dirt or other foreign substances will not be considered defective.

THE EXPRESS WARRANTY SET FORTH ABOVE CONSTITUTES THE ONLY WARRANTY APPLICABLE TO REFRIGERATING SPECIALTIES PRODUCTS, AND IS IN LIEU OF ALL OTHER WARRANTIES, EXPRESSED OR IMPLIED, WRITTEN OR ORAL, INCLUDING ANY WARRANTY OF MERCHANTABILITY, OR FITNESS FOR A PARTICULAR PURPOSE. No employee, agent, dealer or other person is authorized to give any warranties on behalf of Refrigerating Specialties, nor to assume, for Refrigerating Specialties, any other liability in connection with any of its products.

Safe Operation (See also Bulletin RSBCV)

People doing any work on a refrigeration system must be qualified and completely familiar with the system and the Refrigerating Specialties Division valves involved, or all other precautions will be meaningless. This includes reading and understanding pertinent Refrigerating Specialties Division product Bulletins, and Safety Bulletin RSB prior to installation or servicing work.

Where cold refrigerant liquid lines are used, it is necessary that certain precautions be taken to avoid damage which could result from liquid expansion. Temperature increase in a piping section full of solid liquid will cause high pressure due to the expanding liquid which can possibly rupture a gasket, pipe or valve. All hand valves isolating such sections should be marked, warning against accidental closing, and must not be closed until the liquid is removed. Check valves must never be installed upstream of solenoid valves, or regulators with electric shut-off, nor should hand valves upstream of solenoid valves or downstream of check valves be closed until the liquid has been removed. It is advisable to properly in-stall relief devices in any section where liquid expansion could take place or liquid may be trapped between valves.

Avoid all piping or control arrangements which might produce thermal or pressure shock.

For the protection of people and products, all refrigerant must be removed from the section to be worked on before a valve, strainer, or other device is opened or removed.

Flanges with ODS connections are not suitable for ammonia service.

